

A photograph of an industrial conveyor belt system. A worker in a dark cap and light-colored shirt is visible in the center, looking at a document. The scene is dimly lit with blue ambient lighting. Four red corner brackets are overlaid on the image, framing the central text.

PROImage PROLOAD..png **LOAD**

A NEW APPROACH TO THE POINTS OF
TRANSFER OF CONVEYOR BELTS

PREVENT SPILLS. REDUCE DUST. IMPROVE RETURN ON INVESTMENT.

THE HIDDEN COST

Each transfer point
it represents a loss of value

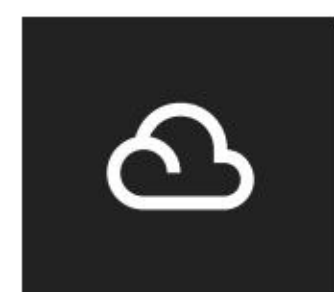

EMISSIONS OF
DUST



LOSS OF
MATERIAL

THEY ACCUMULATE
THE GREAT ONES
BILLS

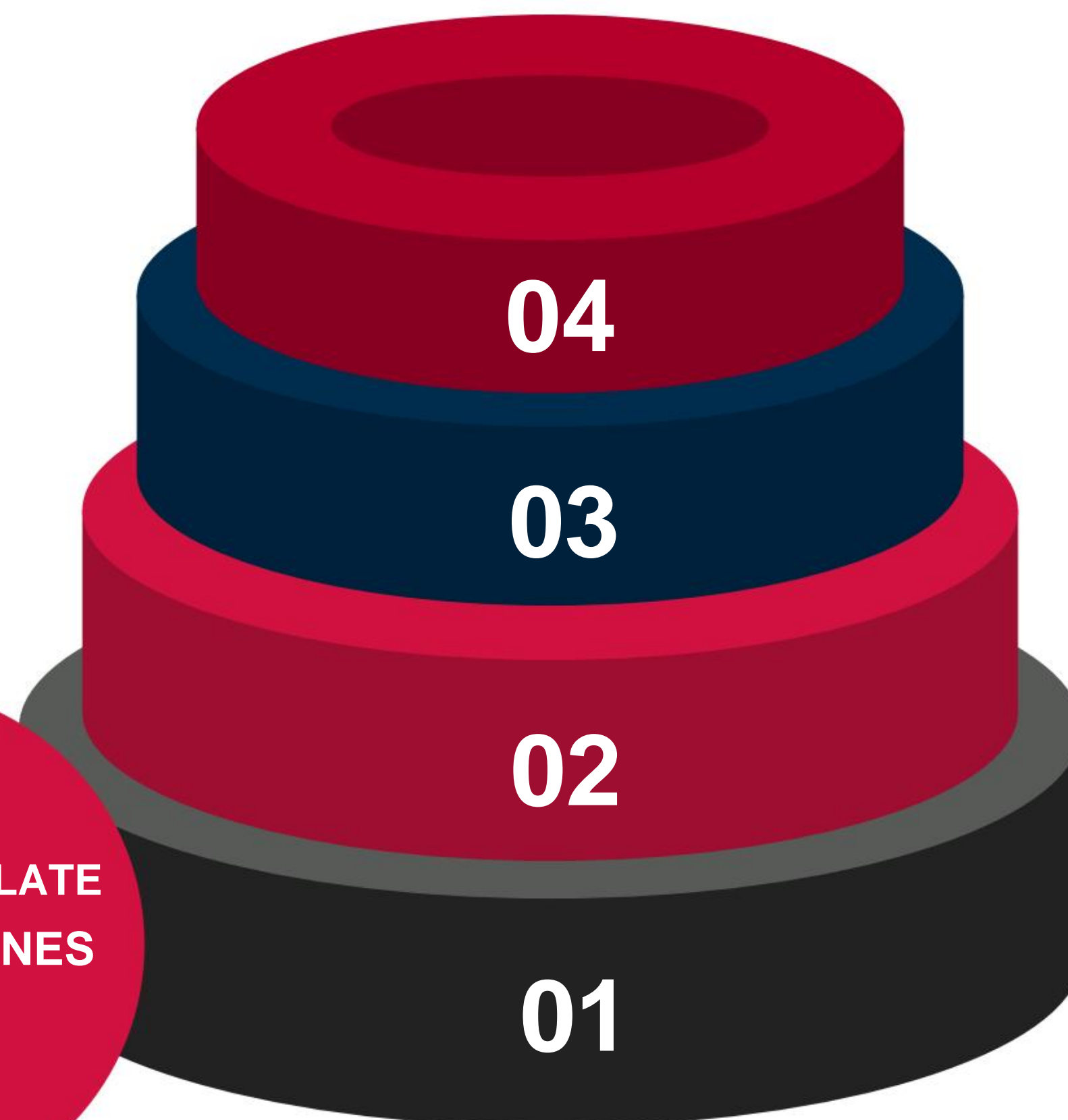

TASKS OF
CLEANING



TIME OF
INACTIVITY





This is still an industry standard

1

DUST CLOUDS
HARMFUL

2

LOW SPILLS
THE TAPES
CONVEYOR MACHINES

3

EFFORTS OF
CLEANING
CONTINUES

4

SYSTEMS
HIGH
MAINTENANCE

WE ACCEPT IT AS NORMAL. BUT IT SHOULDN'T BE THAT WAY.

THE PROBLEM

We are solving the wrong problem



**WE ARE TREATING THE SYMPTOMS.
NOT THE CAUSES.**

THE PARADIGM SHIFT

Prevention? Overcome extraction!

CONTROL MECHANIC

100% mechanical
solution

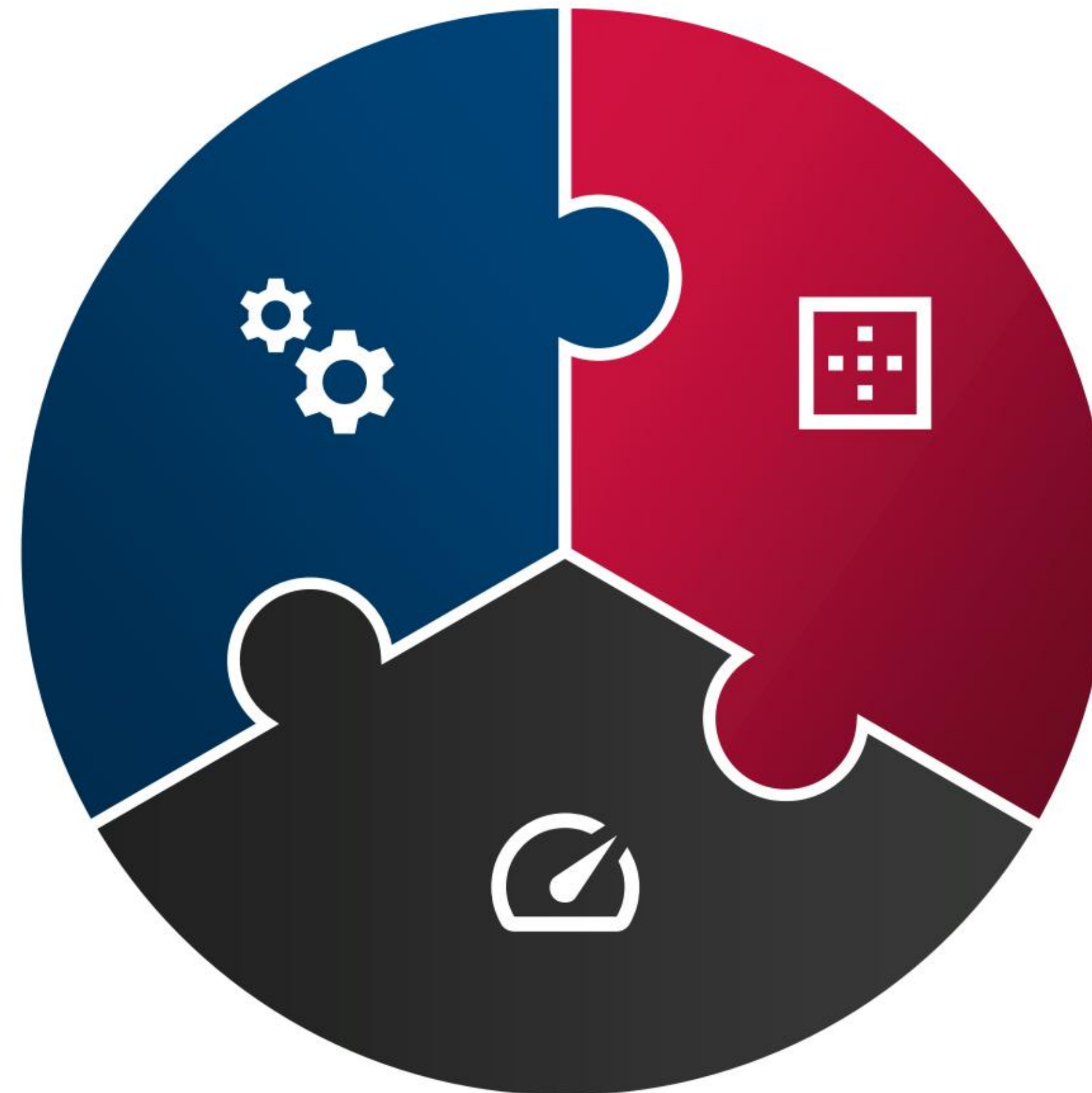

CONTAINMENT OF MATERIALS

Containment of
materials within the system.

SPEED

FROM THE AIR

It reduces dust by slowing down the airflow
inside the system.

BLU-TE C® PRO OLOAD

A mechanical sealing system for conveyor belt transfer points that:



01



Eliminates material loss

02



Reduces dust

03



Improve efficiency



「 WHAT MAKES IT DIFFERENT? 」
A closed system instead
of an open problem



**Continuous tape
support**



**Hermetically sealed
structure**



**No gaps, no
leaks**

STEP 01

Avoid spills

ARE THERE NO GAPS?

THERE IS NO ESCAPE WAY FOR THE MATERIAL.



BEFORE



AFTER

- 1 Controlled loading zone.
2. Gutter inclined at 70 degrees.
- 3 Reduction of impact turbulence.

STEP 02



BEFORE

Reduce dust formation to decrease air speed

LESS DUST GENERATED ON IMPACT.

AFTER



1 Strap secured along its entire length.

2 There should be no gaps between the belt and the joints.

3 Dynamic side sealing.

STEP 03

To contain
and settle the dust

THE DUST STAYS INSIDE THE SYSTEM.



BEFORE



AFTER

- 1 Several airtight compartments.
- 2 Decrease in air speed as the material moves forward.
- 3 The powder is reintegrated into the material flow.

PREDICTABLE TRANSFER POINTS

From open chaos to controlled flow



BEFORE

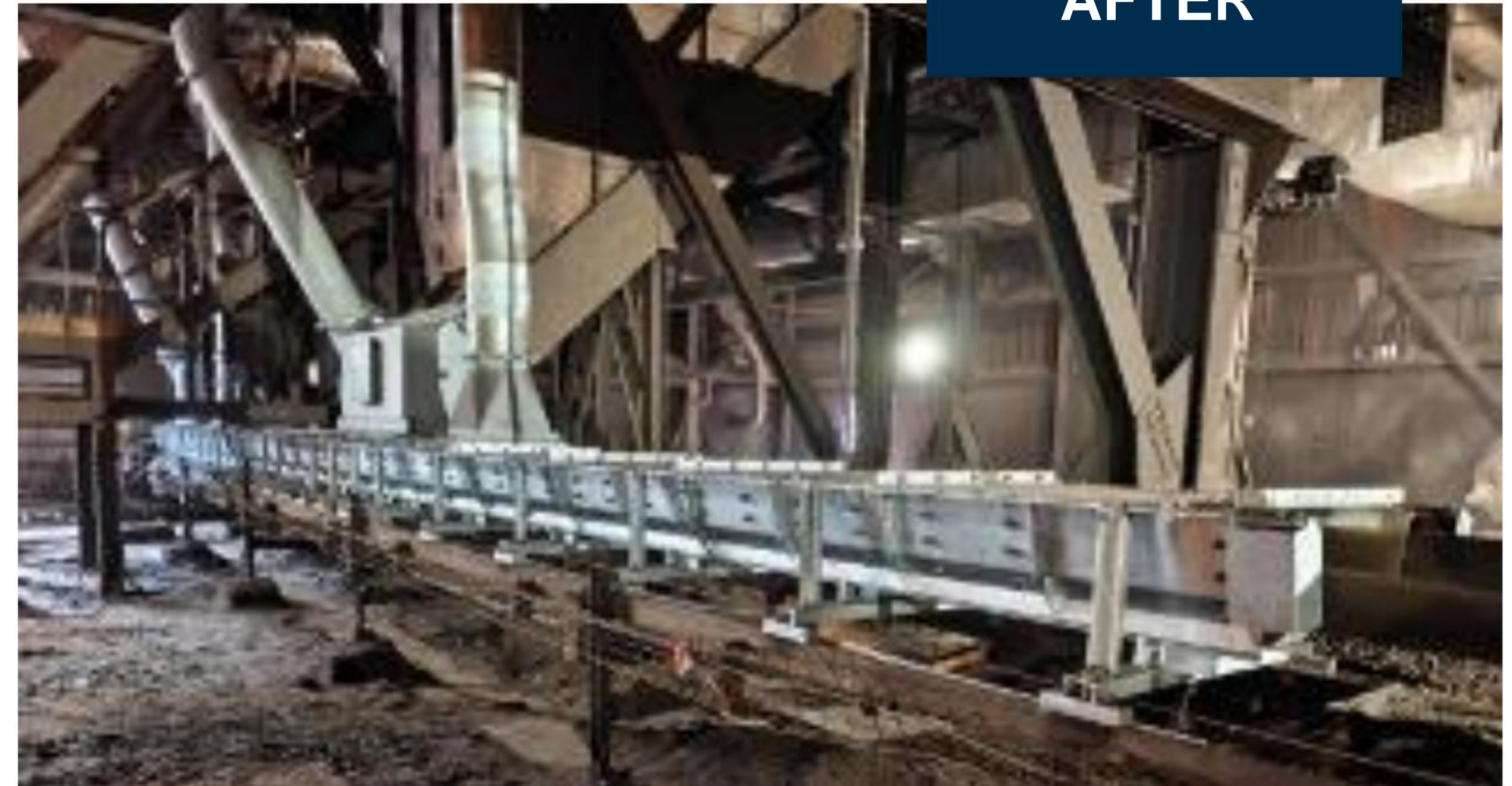

AFTER



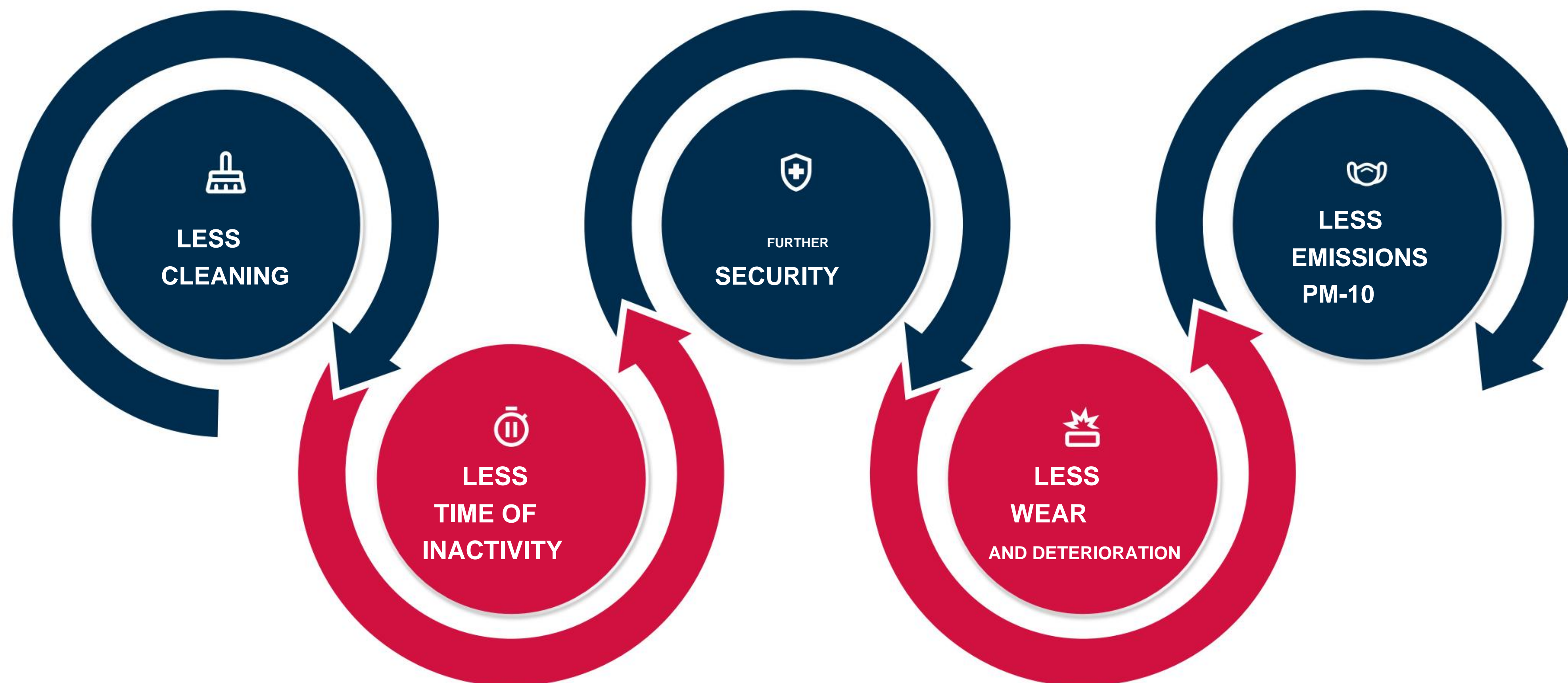

TO SIMPLIFY OPERATIONS

Main advantages





Designed to offer reliability

-  **Modular system**
-  **Easy adaptation**
-  **Robust construction**
-  **Product compatibility**



COMPARISON

Proload vs Traditional Extraction

TRADITIONAL EXTRACTION

BLU-TEC® PROLOAD

REDUCTION
FROM DUST

95-99%

80-95%

SPILL
MATERIAL

RESOLVED

DELETED

CONSUMPTION OF
ENERGY

HIGH

VERY LOW

INTENSITY OF
MAINTENANCE

HIGH

VERY LOW

COMPARISON

CAPEX

SYSTEM OF
EXTRACTION

BLU-TEC®
PROLOAD

100%

- 75%
DIFFERENCE

~ 25%

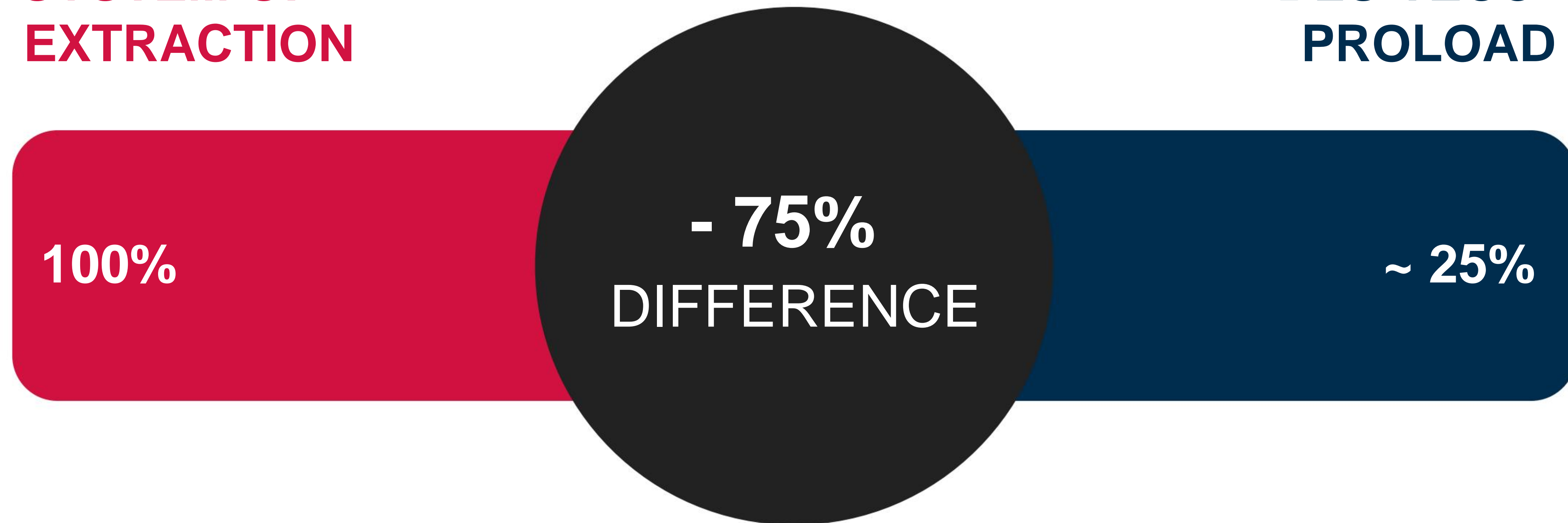

[COMPARISON]

Annual operating expenses (OPEX)

**SYSTEM OF
EXTRACTION**

**BLU-TEC®
PROLOAD**

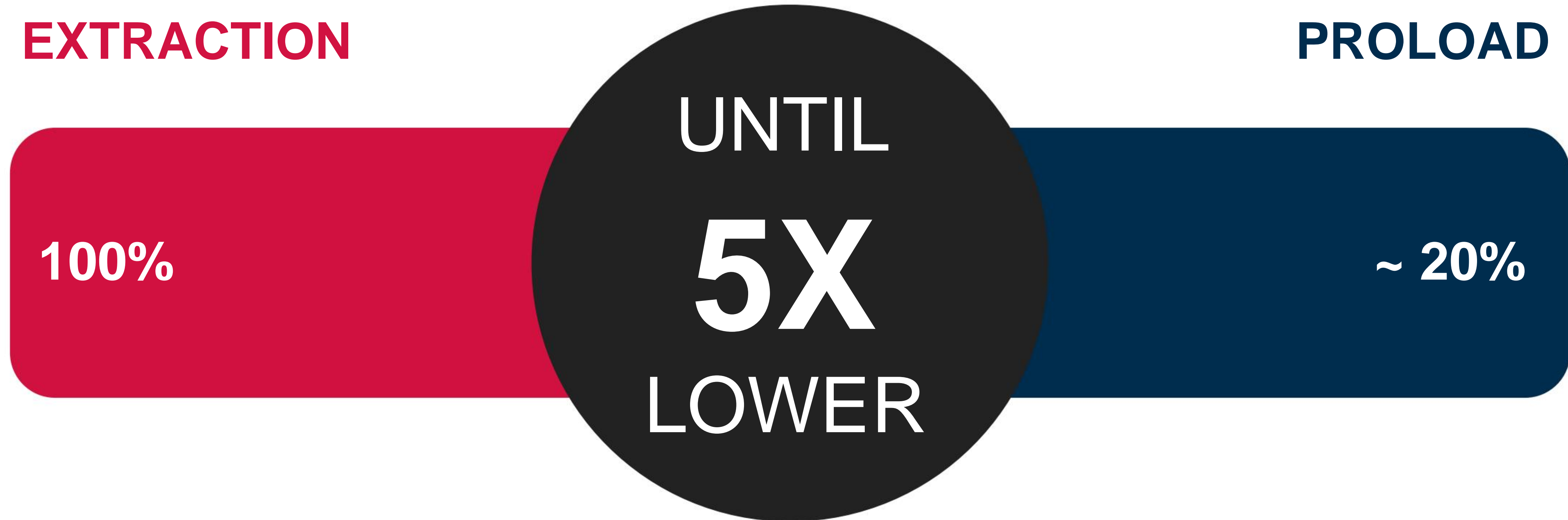

COMPARISON

Total cost of ownership over 5 years (TCO)

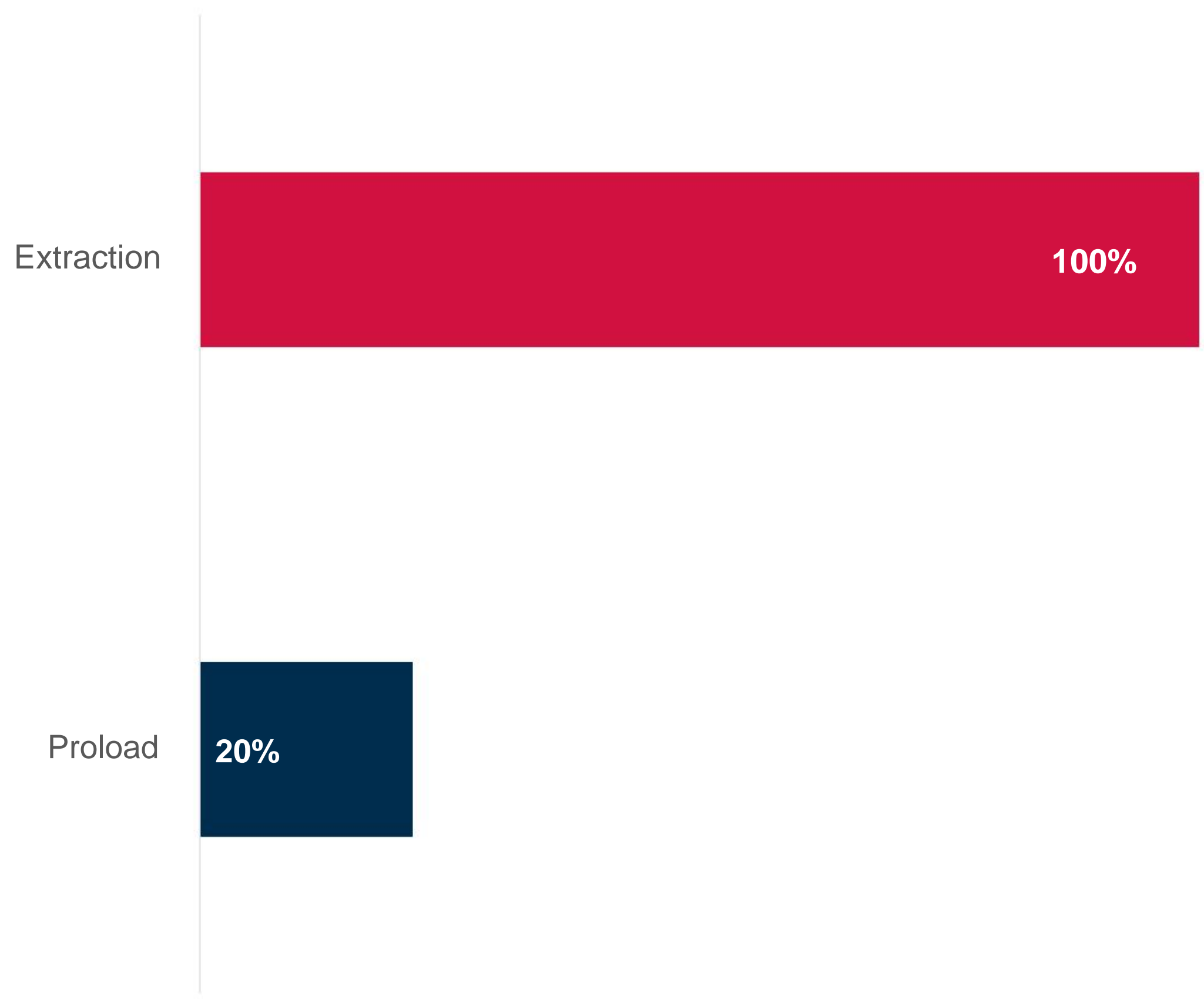

APPROXIMATELY
80%
LOWER COST



Return on investment

592% ROI

IMMEDIATE AMORTIZATION

THE EFFICIENCY IS AN EFFECT OF THE SIMPLICITY

Proven performance

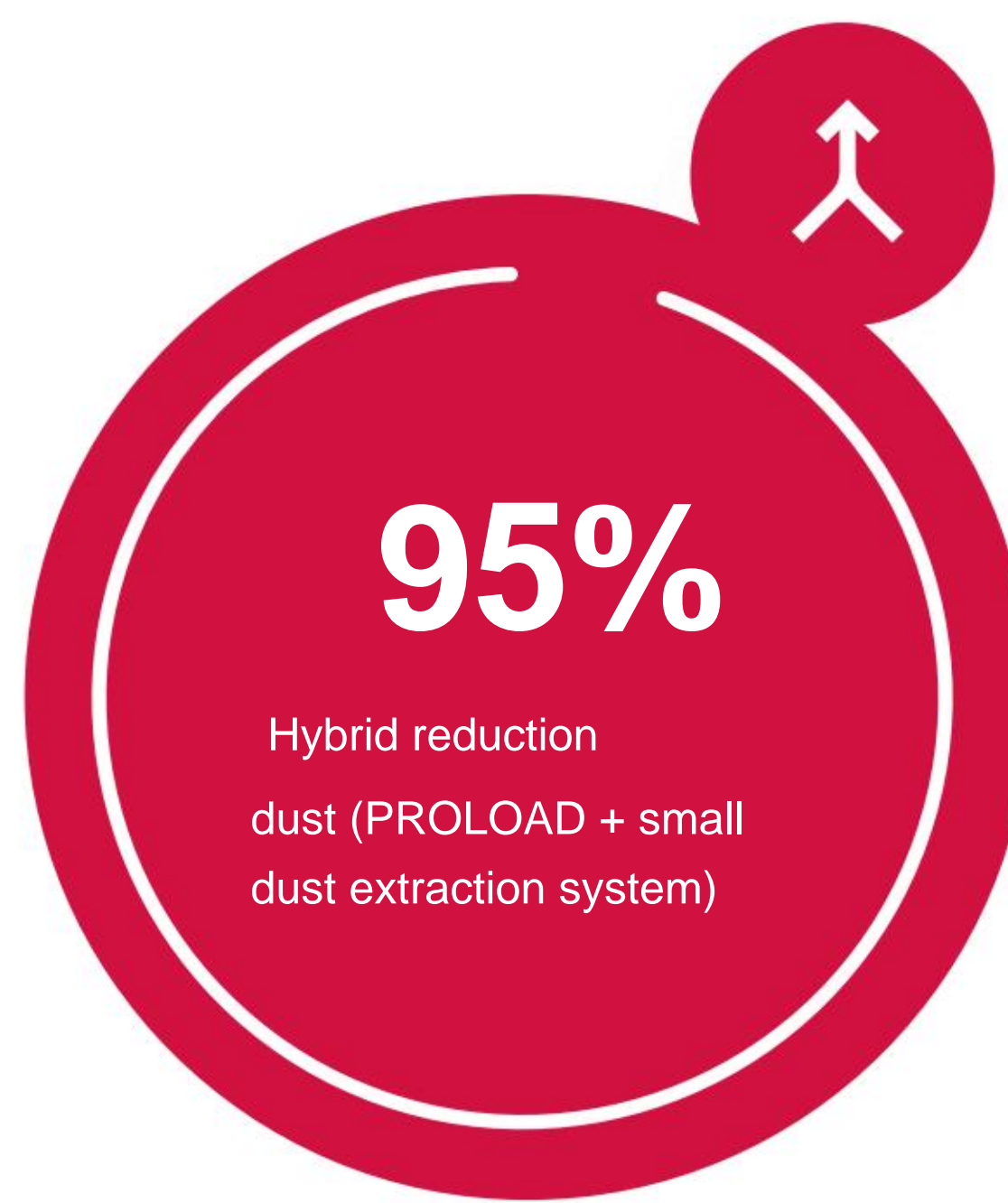
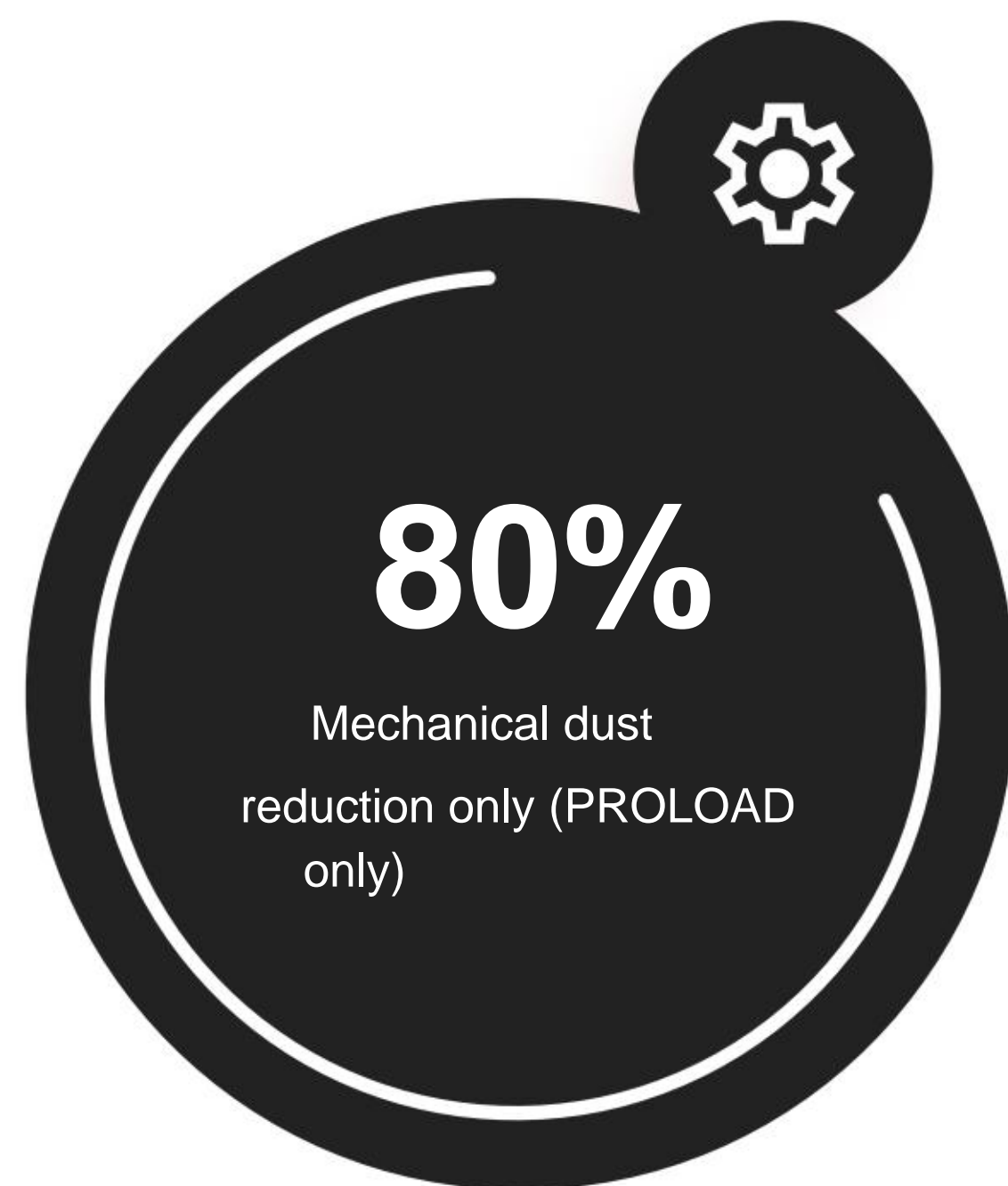

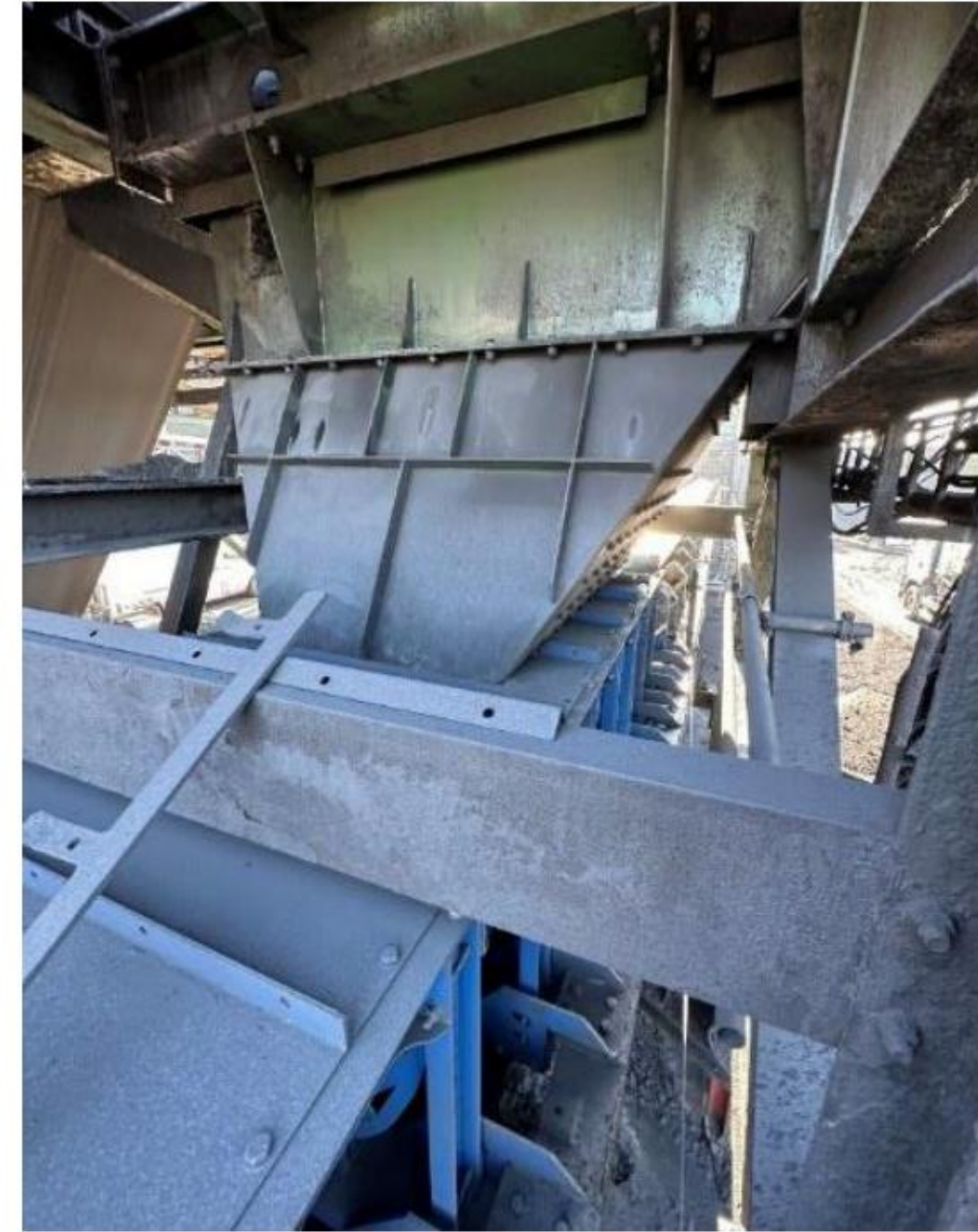

Case study 01

Belt

1600mm Steelcord ST1000 @ 1.9m/sec

Product

Cokes @ 500 T/h

Proload

Extra Heavy Duty, C5 coating, ceramic wear plates , 6 meters long



Case study 02

Belt

1400mm Steelcord ST1600 @ 1.7m/sec

Product

Coke, iron ore (bulk density 1.7–3.3 T/m³), 2,900 T/h

Proload

Extra Heavy Duty C5 coating, ceramic wear plates , 6 meters long



Case study 03

Belt

1400mm ST1600

Product

Iron ore, particle size 0–2 mm, 4000 t/h

Proload

Heavy Duty, with hot-dip galvanized coating
Hot-rolled and ceramic wear plates; length: 6 meters. With repositioning of the reversing pulley to ensure adequate feed length.

APPLICATIONS

Applicable to all sectors

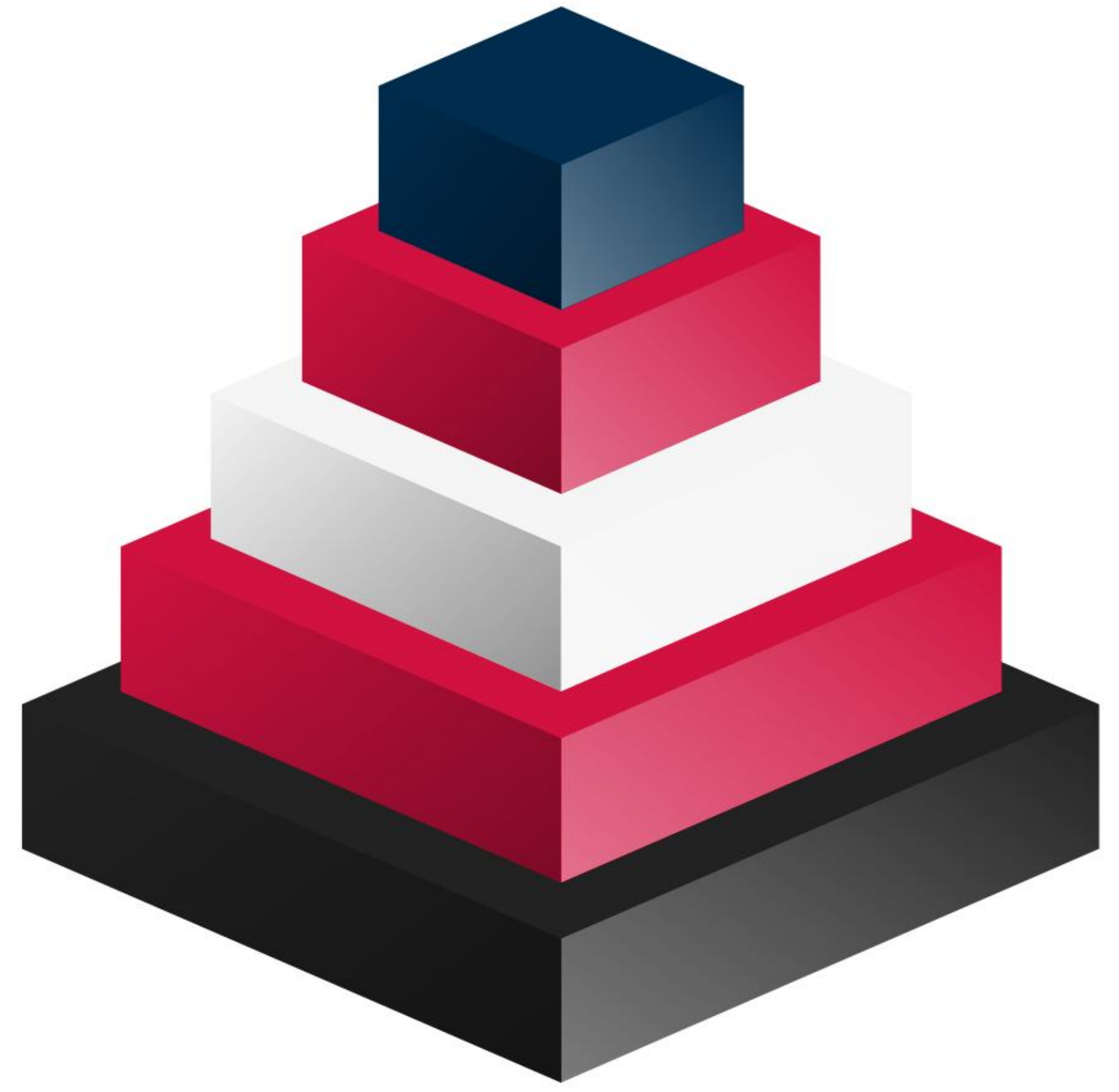

MINING

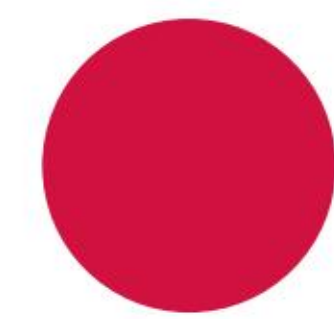

CEMENT



STEEL

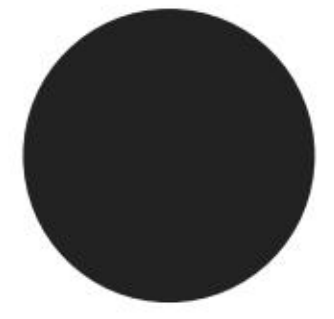

**HANDLING
OF PRODUCTS
IN BULK**



**PRODUCTS
CHEMICALS**

FLEXIBLE AND SCALABLE DESIGN

Normal, Heavy and Extra heavy duty models with multiple material options



TO REMEMBER

Key points of today



Avoid spills



Improves reliability

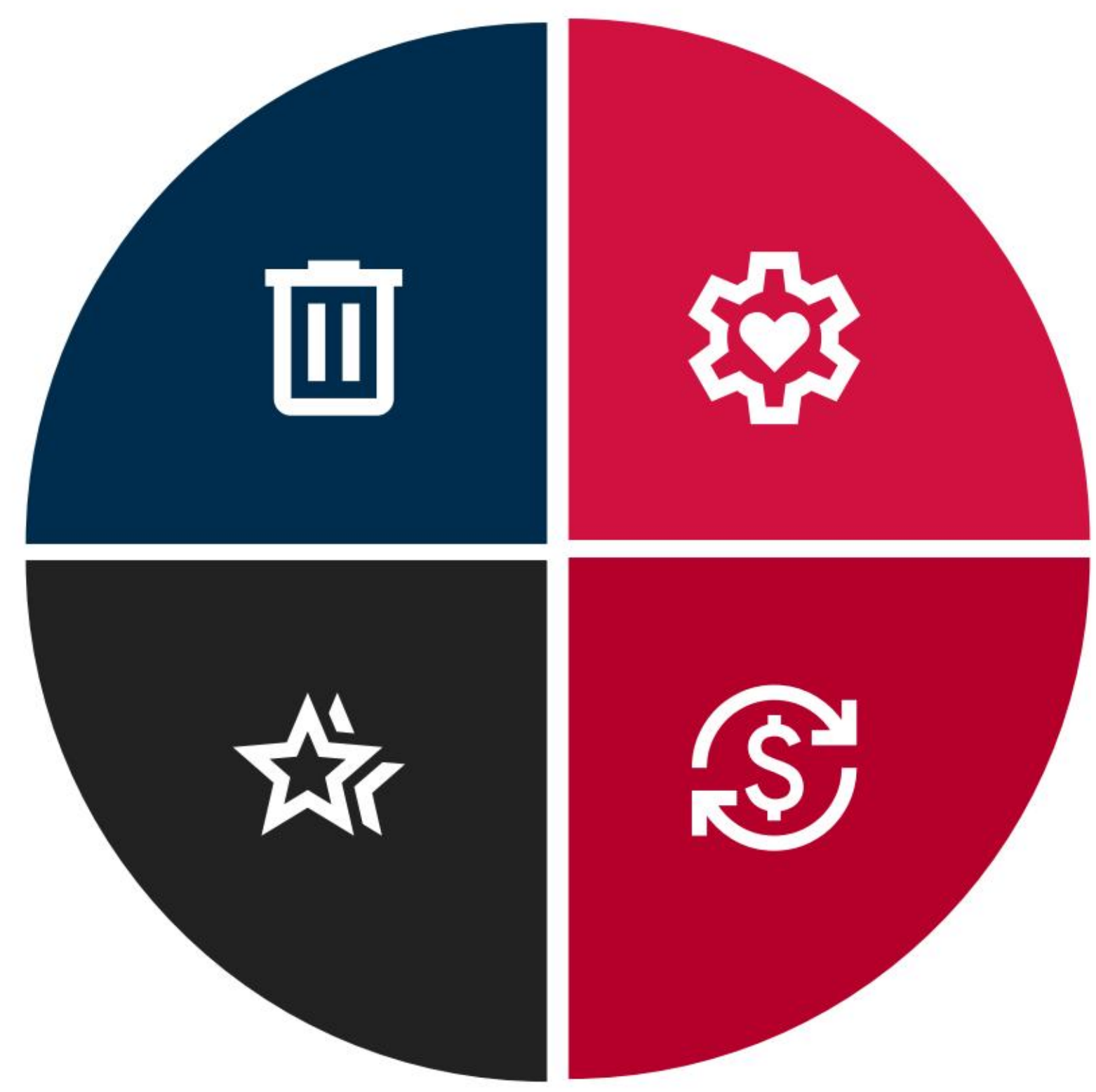

It reduces dust mechanically.



Low CAPEX & OPEX





Economic and Operational Impact

Return on investment (ROI):



SUPERIOR ROI

ROI greater than 592%



FOR EVERY USD 1 INVESTED

More than USD 5 in profit is generated



IT IS NOT A COST

It is a highly profitable investment

Return on investment:



EXTREMELY SHORT PAYBACK

In many cases less than 3 to 6 months



IN CRITICAL OPERATIONS

It can be practically immediate.

SUMMARY

Benefits key operational

**PAYMENT IS MADE IN MONTHS ONLY.
THE OPERATION THEN GENERATES
CONTINUOUS SAVINGS**

DUST REDUCTION

80-95%



ANNUAL AM IMPIEZ DECREASE 60-80%



REDUCTION OF SPILLS

1 00%



INCREASED AVAILABILITY

+8-1 5%

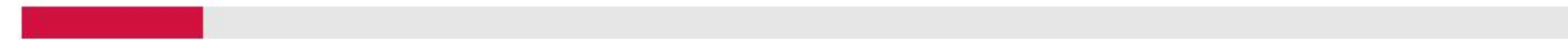

RECOVERY OF FINE MATERIAL

70-90%



REDUCTION IN ENERGY CONSUMPTION

90%



STRATEGIC CONCLUSION

Proload transforms an operational problem in a direct economic advantage

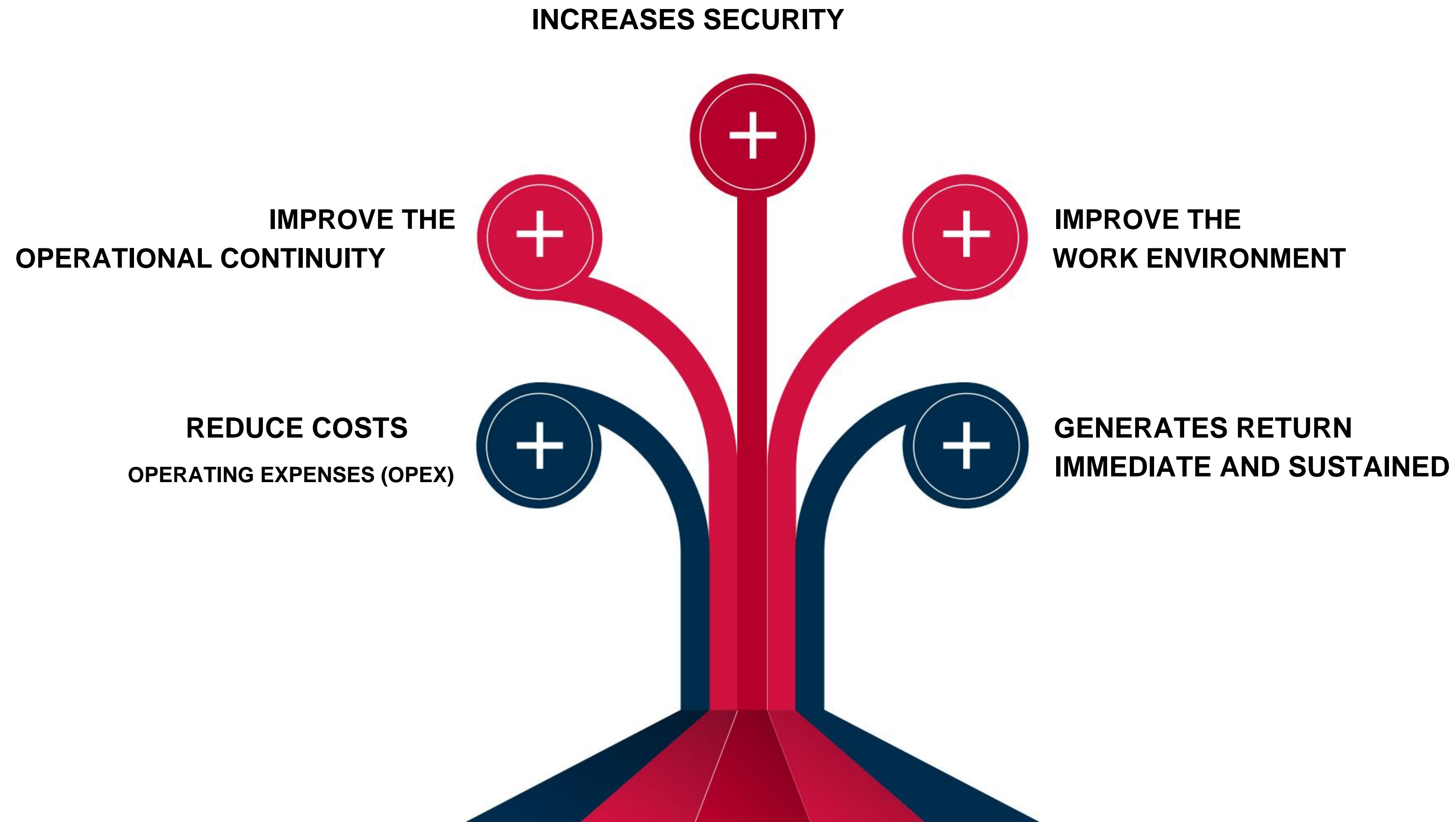

Proload



**AVOID SPILLS.
STOP EXTRACTING THE DUST.
START PREVENTING IT.**





Let's analyze your transfer points

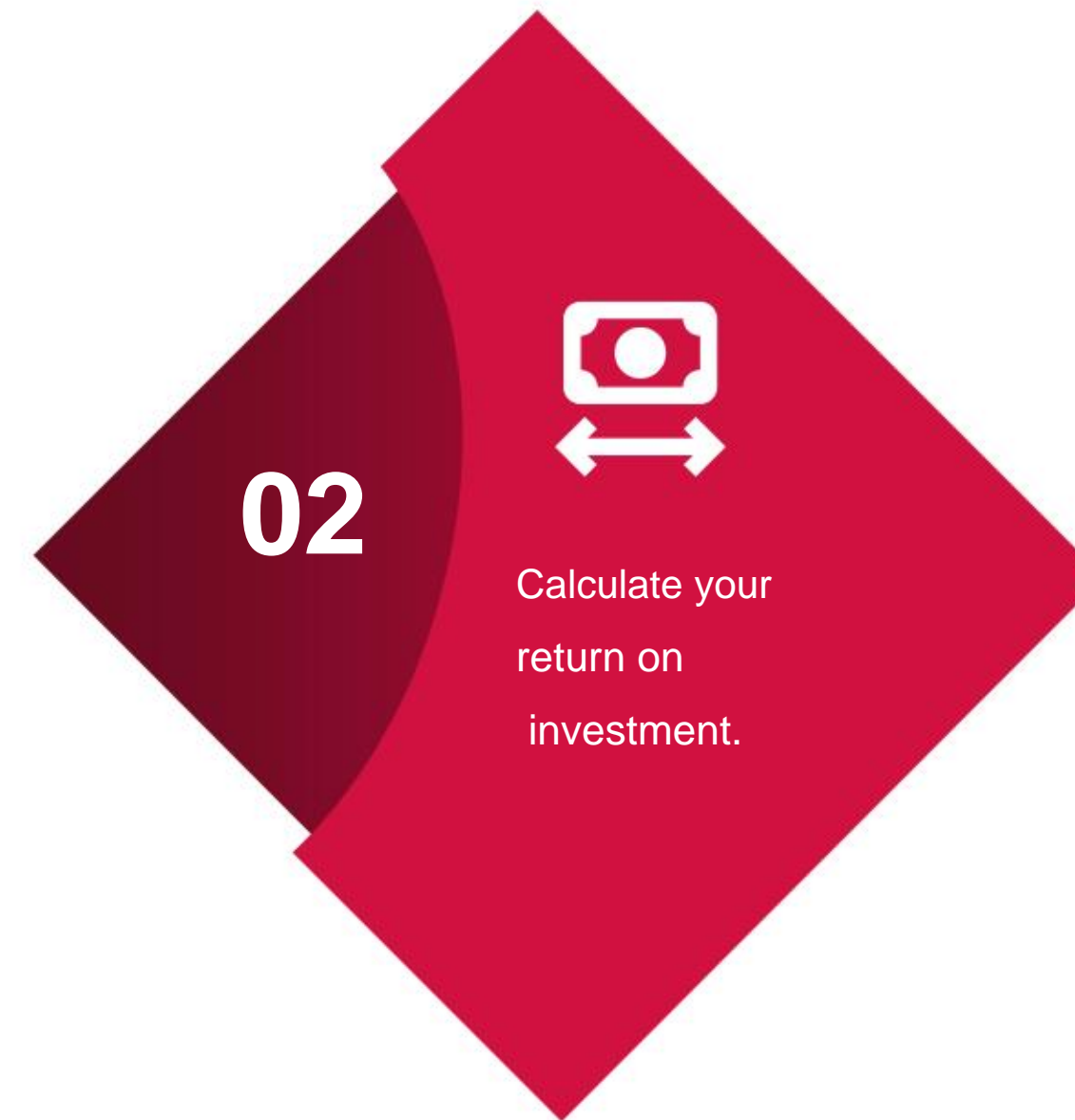

SCRAPERS

For optimal cleaning of your conveyor belt



RASPAD OR ESINFERI OR ES

Belle Banne U

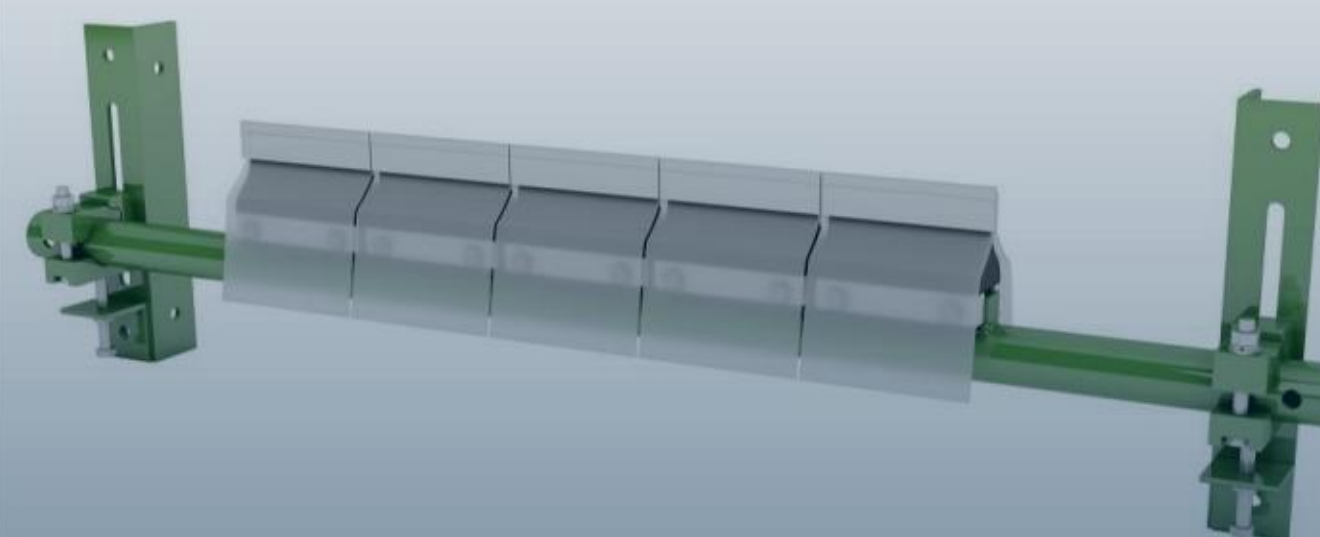

RASPAD OR ESINFERI OR ES

Belle Banne R

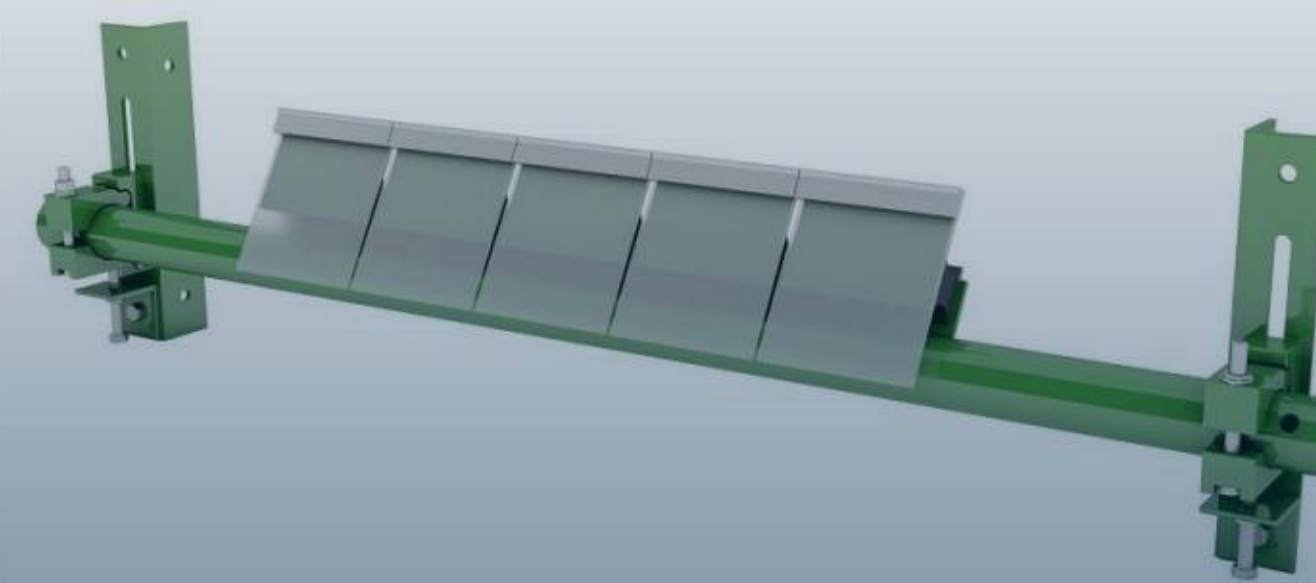

RASPAD OR ESINFERI OR ES

Belle Banne P

SCRAPERS

For optimal cleaning of your conveyor belt

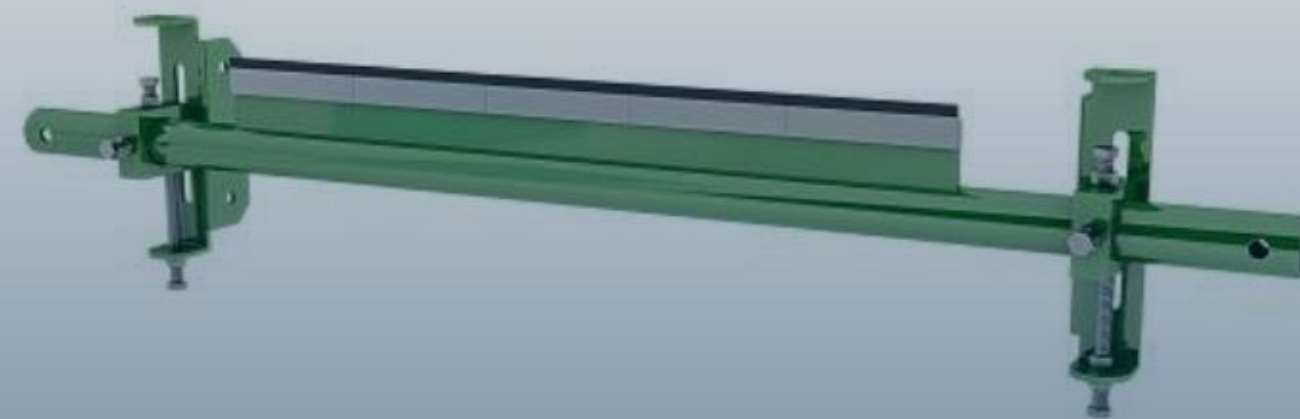

RASPAD OR ESINFERI OR ES

Promati Type KS & KS

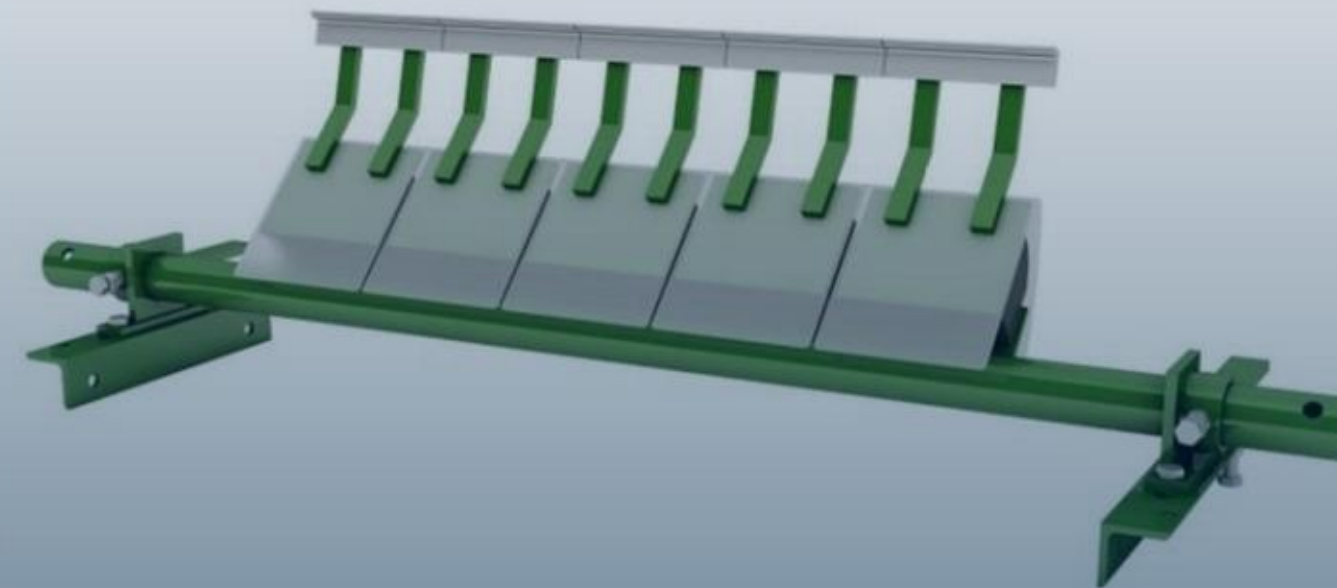

RASPAD OR ESINFERI OR ES

Belle Banne H

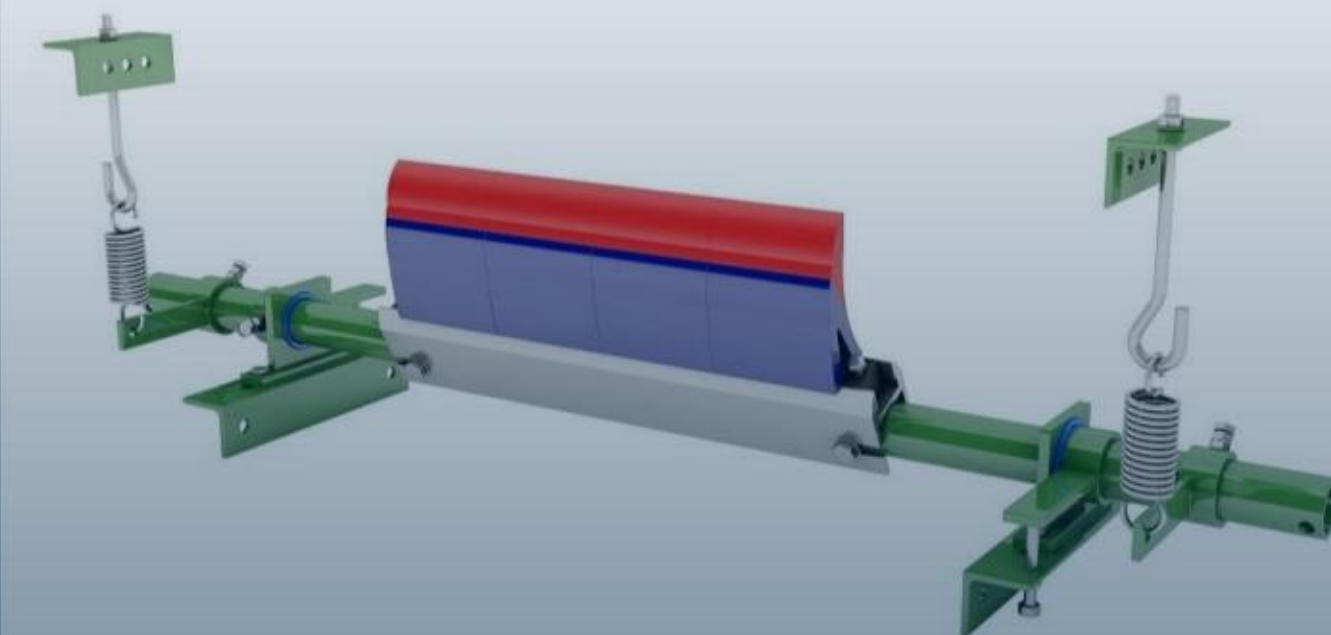

RASPAD OR HEAD

Promati TPH

THANK YOU

THANK YOU FOR YOUR TIME AND INTEREST

SERVINGE LATAM

San Sebastian No. 2750,
Office 902, 3rd floor,
Las Condes,
Santiago, Chile

www.servingelatam.com

PROMATI

Chaussée de Wavre 362
1390 Grez-Doiceau
Belgium

www.promati.com

Promati Netherlands

Nikkelstraat 45
4823 AE Breda
Netherlands

Promati Germany

Florinstraße 23
56218 Mühlheim - Kärlich
Germany